

HAZARDOUS LOCATION

Configuration Code XP04 Hazardous Location Explosion-Proof-Certified, Thermocouple Assemblies with Thermowells

Explosion-Proof Thermocouple Assemblies with Thermowells are made for use in U.S. and Canadian hazardous areas. They are designed to extinguish flames inside the device, eliminating the potential for ignition of flammable mixtures in the surrounding atmosphere. FM and CSA certified assemblies, dependent on connection head type, meet XP Class I Division I & II; Groups A, B, C, D; DIP Class II Division I; Groups E, F, G; Class III; Type 4/4X. The required thermowell is available in standard, heavy-duty, and flanged constructions. The assemblies feature 316 stainless steel sheaths and ungrounded isolated junctions. They are available with aluminum or stainless steel explosion-proof connection heads.

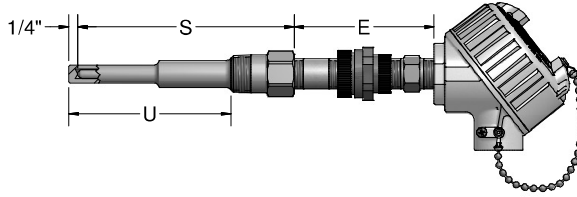

ORDER CODES

Example Order Number:

1-0 2-1 2-2 2-3 3-0 4-0 5-0 5-1 5-2
XP - J 48 U - **- SL - 8XU4 94, I**

1-0 Agency Approval

CODE	DESCRIPTION
XP	FM/CSA explosion-proof-certified assembly

2-1 Thermocouple Types

CODE		
SINGLE	DUPLEX	TRIPLEX
E	EE	-
J	JJ	JJJ
K	KK	KKK
T	TT	-

2-2 Sheath Diameters 316 SS

CODE	DIAMETER (inches)
48	1/4

2-3 Measuring Junction

CODE	DESCRIPTION
U	Ungrounded

3-0 Thermowell

Select thermowell from Thermowell Section.

4-0 Element Options

SL ^[1]	Spring-loaded element
SC	Self-contained spring-loaded element

[1] Not available with option 75T, 76T, or 77T

5-0 Head Mounting Fittings

CODE	DESCRIPTION	CODE	DESCRIPTION
<i>STEEL FITTINGS</i>		<i>316SS FITTINGS</i>	
6HN	1/2" x 1/2" NPT hex nipple 1" length	8HN	1/2" x 1/2" NPT hex nipple 1" length
6PN ₋	1/2" NPT pipe nipple (specify "E" length in inches)	8PN	1/2" NPT pipe nipple (specify "E" length in inches)
6XU ₋ ^[1]	1/2" NPT union/nipple (specify "E" length in inches)	8XU ₋ ^[1]	1/2" NPT union/nipple (specify "E" length in inches)

[1] 3 1/2" minimum length required
Maximum allowable "E" length is 9"

5-1 Head Terminations

CODE	DESCRIPTION
74	DIN form B aluminum explosion-proof head
75T-642B	(4 to 20) mA HART® Field Transmitter with aluminum explosion-proof housing
76T82-D10	(4 to 20) mA dual input HART® Field Transmitter with digital display and explosion-proof aluminum housing
77T-662C	(4 to 20) mA HART® Field Transmitter with dual cavity explosion-proof aluminum housing
93	Aluminum explosion-proof head
94	316L stainless steel explosion-proof head

5-2 Options

SB	1/2" NPT conduit reducer bushing
I	Stainless steel tag
T-441	(4 to 20) mA isolated head-mounted transmitter
T-442	(4 to 20) mA HART® isolated head-mounted transmitter
T82-00	(4 to 20) mA dual input, isolated HART® head-mounted transmitter

See transmitter ordering information in back of section.

HART® is a registered trademark of the HART Communication Foundation.



The drilled thermowells listed below are those most commonly found in process applications. Other types and styles are listed later in this section. The thermowells listed below are available as separate component wells and can be ordered by the code numbers listed below. They can also be ordered as a part of a complete sensor assembly. Consult factory for wells with different mounting threads, lengths, and materials.

STANDARD-DUTY WELLS

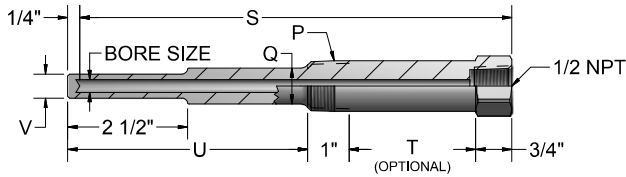

STRAIGHT-SHANK, SOCKET-WELD

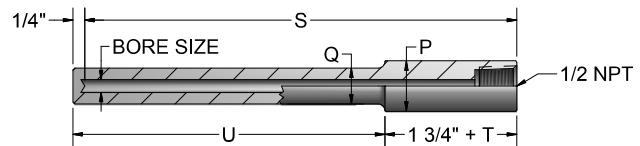

HEAVY-DUTY WELLS

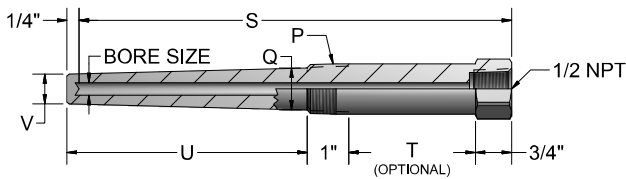

WELD-IN WELLS

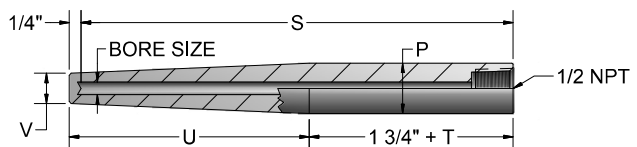

ORDER CODES

Example Order Number:

1-0 1-1 1-2 1-3 1-4 1-5 1-6
S 4 D 06 08 T2 S

1-0 Well Type

CODE	DESCRIPTION
S	Standard-duty threaded (NPT)
H	Heavy-duty threaded (NPT)
SW	Straight-shank, socket-weld
WI	Weld-in

1-1 Bore Size

CODE	DESCRIPTION
4	0.260 Dia. Bore

1-2 Pipe Size "P"

CODE	DESCRIPTION
C	1/2" Pipe ^[1]
D	3/4" Pipe
E	1" Pipe

[1] Only available with well type S or H

1-3 Length Dimensions (inches)

CODE	"S" DIMENSIONS	"U" DIMENSIONS	
		NO LAG	WITH STANDARD LAG
04	4	2(1/2)	N/A
06	6	4(1/2)	2(1/2)
09	9	7(1/2)	4(1/2)
12	12	10(1/2)	7(1/2)
15	15	13(1/2)	10(1/2)
18	18	16(1/2)	13(1/2)
24	24	22(1/2)	19(1/2)

1-6 Well Options

CODE	DESCRIPTION
C8	316 stainless steel well cap and chain
C22	Brass well cap and chain
S	Customer specified part number marked on the thermowell - (10 digit maximum)

1-5 Optional "T" Lag Dimension

CODE	DESCRIPTION
Leave blank if No Lag is required	
T2	2" Lag standard on 6" well
T3	3" Lag standard on 9, 12, 15, 18, 24" wells
T	Special Lag specify "T" dimension in inches

1-4 Material

CODE	DESCRIPTION
08	316 stainless steel
09	304 stainless steel

The flanged thermowells described on this page are those commonly found in most process applications. These wells are supplied as standard- or heavy-duty with raised-faced flanges. Other types and styles are listed later in this section. Consult factory for wells with different flange sides, lengths, and materials.

FLANGED THERMOWELLS

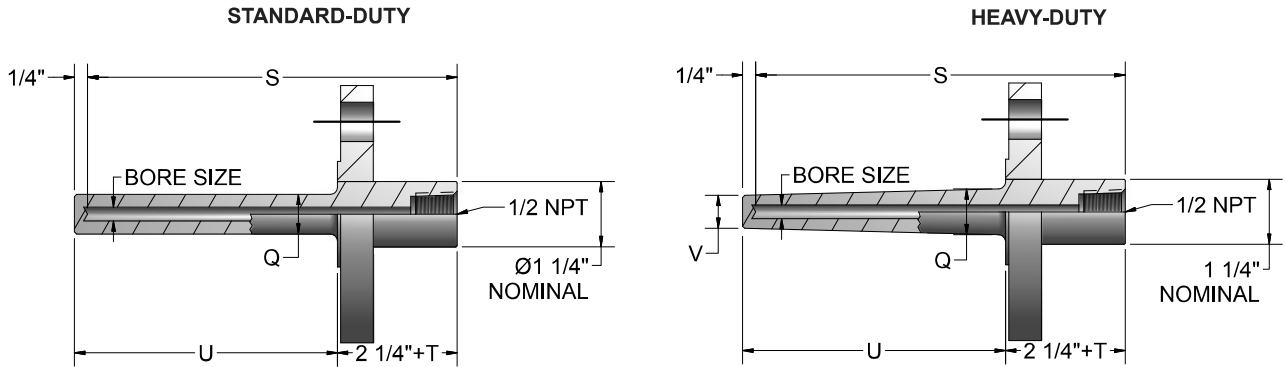

ORDER CODES

Example Order Number:

1-0 1-1 1-2 1-3 1-4 1-5 1-6 1-7 1-8
SF 4 15 R 3 12 08 T2 C8

1-0 Well Type

CODE	DESCRIPTION
SF	Standard-duty flanged
HF	Heavy-duty flanged

1-1 Bore Size

CODE	DESCRIPTION
4	0.260 Bore

1-2 Flange Size

CODE	DESCRIPTION
10	1"
15	1 1/2"
20	2"

1-3 Flange Type

CODE	DESCRIPTION
R	Raised face

1-4 Pressure Rating

CODE	DESCRIPTION
1	150 class
3	300 class

1-8 Well Options

CODE	DESCRIPTION
C8	316 stainless steel well cap and chain
C22	Brass well cap and chain
S	Customer specified part number marked on thermowell (10 digit maximum)

1-7 Optional "T" Lag Dimension

CODE	DESCRIPTION
	Leave blank if no lag is required
T__	Specify "T" dimension in inches

1-6 Well Material

CODE	DESCRIPTION
08	316 Stainless steel
09	304 Stainless steel

1-5 Well Length (inches)

CODE	DESCRIPTION	
	"S" DIMENSION	"U" DIMENSION
06	6	4
09	9	7
12	12	10
15	15	13
18	18	16
24	24	22