

## Easily Adapted to Many Non-Pressurized HVAC Systems

Constructed of sturdy 0.430 in. (11 mm) diameter WATROD™ heating elements mounted to a 1/4 in. (6 mm) thick steel flange, duct heaters are easily adapted to many non-pressurized air-heating systems.

They are easily installed in applications requiring a wide range of temperature versus air flow combinations.

The modular duct heater offers increased reliability. The individual modules are removable through the housing of the assembly, which eliminates the need to pull the complete heater from the duct work. This reduces downtime costs because the heating elements can be replaced individually. Performance improvements include quicker response time and reduced infiltration from the air stream being heated into the electrical enclosure.

Watlow® duct heaters offer advantages over gas or oil fired and open coil electric units with:

- Installation flexibility—no flues or fuel lines
- 100% energy efficient—no energy loss up the flue
- Universal availability of electricity
- Resistance coil in sheath is protected from corrosive environments

### Performance Capabilities

- Watt densities up to 40 W/in<sup>2</sup> (6.2 W/cm<sup>2</sup>)
- Recommended process temperatures from -20 to 1200°F (-29 to 650°C)
- Catalog P/N wattages to 225kW
- Voltages up to 600VAC

### Features and Benefits

#### Long life alloy 840 sheath

- Resists corrosion/oxidation while protecting resistance coils against contamination

#### MgO insulation filled elements compacted to rock hard density

- Maximizes dielectric strength, heat transfer and life

#### Field replaceable heating elements

- Permits easy service and reduces downtime. Element change-out is made simple by a single screw clamp (D SERIES only)

#### 3 1/2 in. (90 mm) thick mineral insulation

- Keeps wiring cooler and reduces heat loss

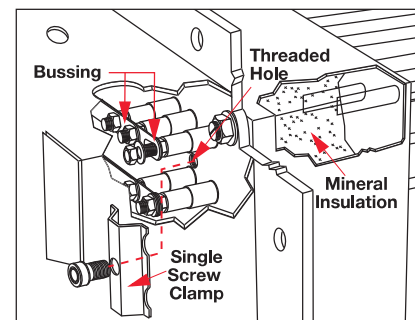

#### Silicone resin seals rated to 221°F (105°C)

- Protects elements against moisture and other contaminants

#### General purpose terminal enclosure

- Offers easy access to wiring

#### 1/4 in. (6 mm) inside diameter thermowell

- Accepts an optional Type J or K thermocouple for accurate sheath temperature sensing (D SERIES only)

#### Rigid stainless steel supports

- Prevents element sagging or deformation in various mounting positions

#### 1/4 in. (6 mm) thick steel flange with 3/8 in. (9.5 mm) diameter mounting holes

- Easily bolts to the duct wall

#### WATROD hairpins are repressed (recompacted) after bending to assure MgO density

- Eliminates hot spots and electrical insulation voids

#### Stock heaters feature from three to 60 elements

- Meets a wide variety of kilowatt demands

#### One or three phase voltages

- Meets local power supplies

#### Maximum 48 amperes per circuit

- Complies with National Electrical Code (NEC)

#### Duct heaters with general purpose enclosures

meet UL® and CSA component recognition to 480 and 600VAC maximum respectively—UL® and CSA file numbers are E52951 and 31388

## Typical Applications

- Drying ovens
- Autoclaves
- Furnaces
- Load banks
- Heat treating
- Reheating
- HVAC
- Paint drying

## Options

WATCONNECT® standard control panels are configured to work with Watlow's duct heaters. They are quickly configured for process heating applications and delivered within two weeks. WATCONNECT panels integrate Watlow's high-quality heater, sensor, temperature controller and power controller products for a complete thermal solution. Normally, competitive custom panels require significantly longer lead times. The broad range of standard features allow customers to quickly configure panels.

### Features and Benefits

#### Lead times of two weeks or less

- Provides faster delivery than competition

#### Full documentation provided for WATCONNECT control panels at the time of quotation

- Eliminates lengthy approval process and phone calls

#### Incorporates Watlow's temperature and power controllers

- Provides a turnkey solution for process heating applications

#### Range of standard input/output (I/O) options

- Provides the user with a higher level of monitoring and control assuring an efficient and safe operation

#### WATCONNECT enclosure easily mounts to wall or frame

- Decreases installation time

**Note:** The WATCONNECT part number associated with a heater is only a suggestion. The following installation details need to be compared to panel capabilities to assure a compatible match:

- Minimum and maximum ambient temperature where panel will be installed
- Statutory and regulatory requirements at installation site
- Sun loading, if any, at installation site
- Presence of any hazardous gases, dusts or fibers, if any
- Verification of process sensor type
- Verification of limit sensor type
- Input/Output (I/O) requirements

For additional product information see the WATCONNECT landing page at [www.watlow.com/watconnect](http://www.watlow.com/watconnect). On the WATCONNECT landing page you will find a complete specification sheet along with other tools to help you properly select your control panel. If you would like to know the specific configuration of a WATCONNECT part number, please use the Product Configuration Lookup Tool on [Watlow.com](http://Watlow.com).



## Wattages/Voltages

To meet specific application needs, voltage and wattage combinations outside stock product parameters are available. For more information about this option, contact a Watlow representative.

## Terminal Enclosures

In addition to the standard, general purpose terminal enclosure, Watlow offers the following optional terminal enclosures to meet specific application requirements:

- Moisture resistant
- Explosion resistant (contact your Watlow representative)
- High-temperature stand-off enclosures

## Sheath Material

Watlow duct heaters can be built with the following sheath materials:

- 304, 316, 321 SS
- Alloy 800
- Laminated alloy 600 (high-temp)
- Hastelloy® C276

Contact a Watlow representative for details and availability.

## Thermocouples

**Type J or K** thermocouples, inserted in the thermowell, accurately sense element sheath temperature for over-temperature conditions.

To sense process temperature, the sensing element should be located downstream from the duct heater. This will eliminate incorrect sensing caused by radiant heat.

Thermocouples are supplied with 120 in. (3050 mm) leads, longer lead lengths are available (this applies to "D" SERIES only). Unless otherwise specified, thermocouples are supplied with temperature ranges detailed on the *Thermocouple Types* chart.

Using a thermocouple requires an appropriate temperature and power controller. These must be purchased separately. Watlow offers a wide variety of temperature and power controllers to meet virtually all applications. Temperature controllers can be configured to accept process variable inputs, too. Contact your Watlow representative for details.

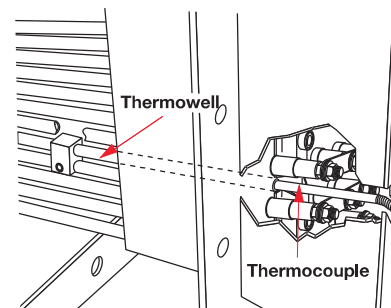

## Options (con't)

### Thermocouple Types

| ASTM Type | Conductor Characteristics  |                              | Recommended <sup>①</sup> Temperature Range |               |
|-----------|----------------------------|------------------------------|--|---------------|
|           | Positive                   | Negative                     | °F   | (°C)          |
| J         | Iron<br>(Magnetic)         | Constantan<br>(Non-magnetic) | 0 to 1000                                  | (-20 to 540)  |
| K         | Chromel®<br>(Non-magnetic) | Alumel®<br>(Magnetic)        | 0 to 2000                                  | (-20 to 1100) |

① **Type J and Type K** thermocouples are rated 32 to 1382°F and 32 to 2282°F (0-750°C and 0-1250°C), respectively. Watlow does not recommend exceeding temperature ranges shown on this chart for the tubular product line.

See Watlow's heater catalog for additional information about choosing a duct heater, required application, watt density, pressure drop, thermocouple types, application types and ordering information.

## Application Hints

- Mount duct heaters horizontally to lower enclosure temperatures and promote unit life.
- Promote heater life by keeping sheath temperature below the 1400°F (760°C) maximum.
- Measure process temperature in the outlet stream, away from the heater.
- Maintain wiring integrity by keeping enclosure temperature below 400°F (205°C).
- Thermal cycling can cause terminations to loosen. Periodically check and tighten all electrical connections.
- Size power feeder wires in accordance with NEC and other applicable codes.
- Protect employees against electrical shock by properly grounding the unit per NEC specifications.

Watlow® is a registered trademark of Watlow Electric Manufacturing Company. WATROD™ is a trademark of Watlow Electric Manufacturing Company. Hastelloy® is a registered trademark of Haynes International. UL® is a registered trademark of Underwriter's Laboratories, Inc. Alumel® and Chromel® are registered trademarks of Hoskins Manufacturing Company.

*Powered by Possibility*



To be automatically connected to the nearest North American Technical Sales Office:

**1-800-WATLOW2 • [www.watlow.com](http://www.watlow.com)**

#### International Technical Sales Offices:

|                |                   |              |                  |                  |                  |
|----------------|-------------------|--------------|------------------|------------------|------------------|
| <b>Austria</b> | +43 6244 20129 0  | <b>India</b> | +91 40 6661 2700 | <b>Mexico</b>    | +52 442 256 2200 |
| <b>China</b>   | +86 21 3532 8532  | <b>Italy</b> | +39 02 458 8841  | <b>Singapore</b> | +65 6773 9488    |
| <b>France</b>  | +33 1 41 32 79 70 | <b>Japan</b> | +81 3 3518 6630  | <b>Spain</b>     | +34 91 675 1292  |
| <b>Germany</b> | +49 7253 9400 0   | <b>Korea</b> | +82 2 2169 2600  | <b>Taiwan</b>    | +886 7 288 5168  |
|                |                   |              |                  | <b>UK</b>        | +44 115 964 0777 |